



FOOD EQUIPMENT

SERVING THE FOOD INDUSTRY SINCE 1951

TABLETOP ECONOMY SERIES BAND SAWS

ITEM: 19457 MODEL: BS-CN-1651 | ITEM: 19458 MODEL: BS-CN-2000



**CUT SLABS OF MEAT
QUICKLY, EASILY, AND PRECISELY**

Omcan's Tabletop Economy Series Band Saws are manufactured in cast aluminum with stainless steel tables. These units offer fine cutting accuracy and ease of use. These saws are ideal for small to medium applications.

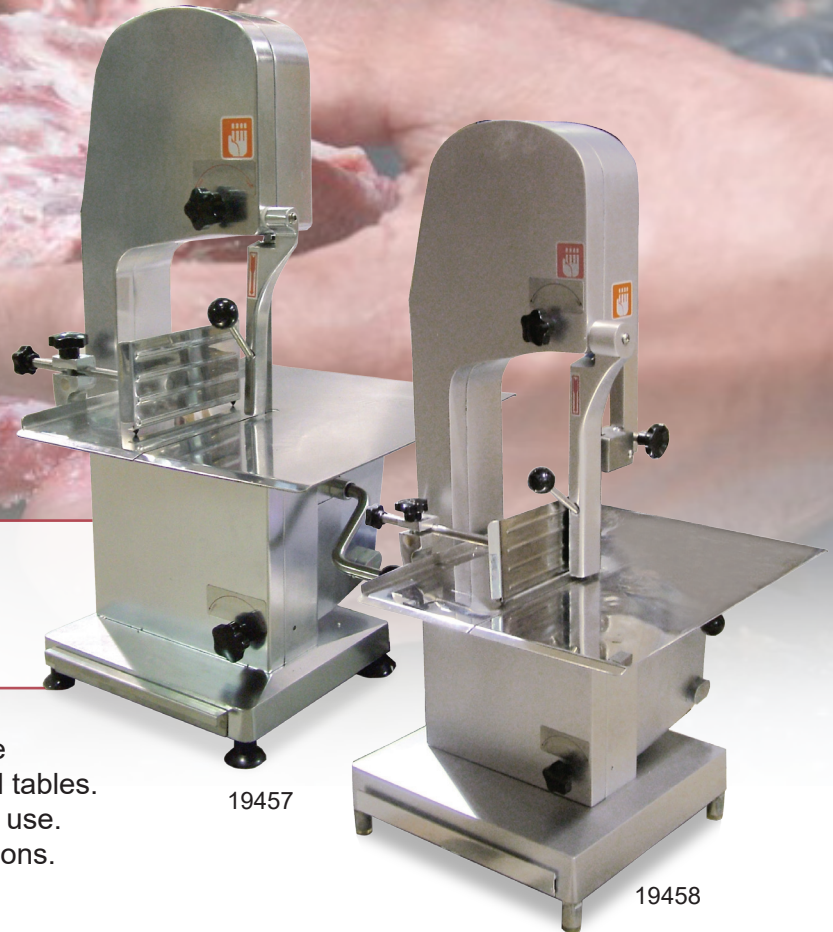

19457

19458



LIMITED WARRANTY
PARTS AND LABOR



SHIPPED ON PALLET

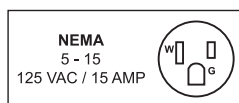

Authorized Dealer

TECHNICAL DRAWING AND DIMENSIONS

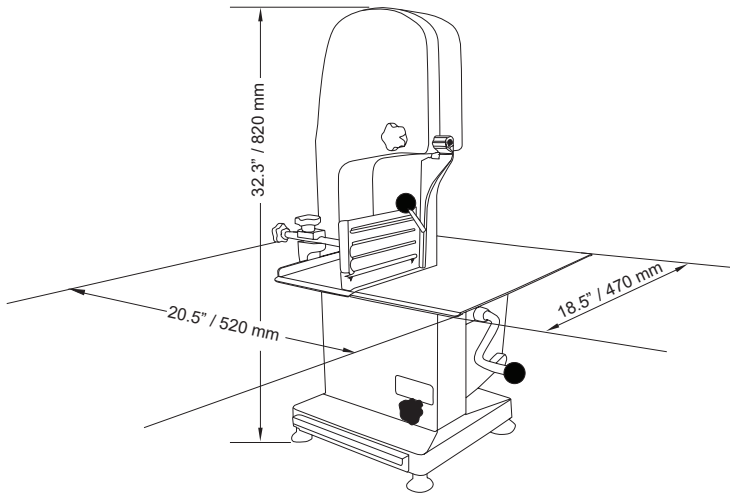

0.87 HP ECONOMY BAND SAW WITH 65" BLADE LENGTH

TECHNICAL SPECIFICATION

ITEM NUMBER	19457
MODEL	BS-CN-1651
BLADE LENGTH	65" / 1651 mm
CUTTING CAPACITY (H*W)	6.75" x 8.25" 171 mm x 210 mm
POWER	0.87 / 0.65 kW
ROTATION SPEED	1420 per minute
ELECTRICAL	110V / 60Hz / 1Ph
WEIGHT	88.2 lbs / 40 kg
PACKAGING WEIGHT	102.5 lbs / 46.5 kg
DIMENSIONS (DWH)	20.5" x 18.5" x 32.3" 520 x 470 x 820 mm
PACKAGING DIMENSIONS	23.2" x 22" x 36.2" 590 x 560 x 920 mm

TECHNICAL DRAWING AND DIMENSIONS

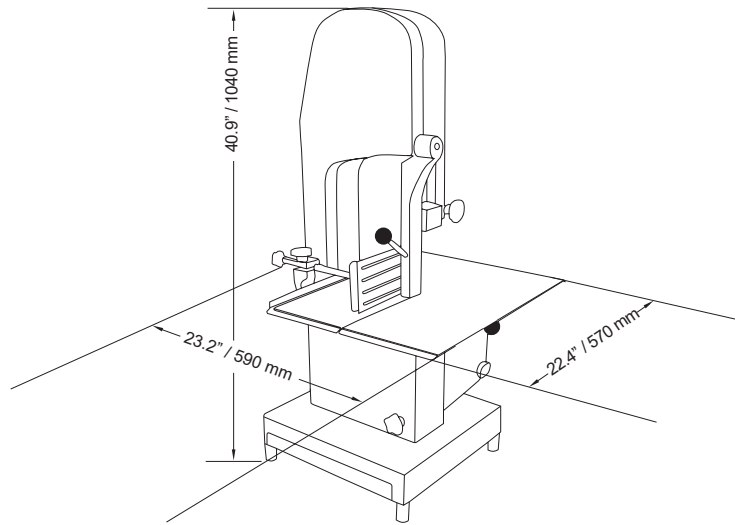

1 1/2 HP ECONOMY BAND SAW WITH 78 1/4" BLADE LENGTH

TECHNICAL SPECIFICATION

ITEM NUMBER	19458
MODEL	BS-CN-2000
BLADE LENGTH	78.75" / 2000 mm
CUTTING CAPACITY (H*W)	7.5" x 12" 191 x 305 mm
POWER	1.5 / 1.12 kW
ROTATION SPEED	1420 per minute
ELECTRICAL	110V / 60Hz / 1Ph
WEIGHT	137.8 lbs / 62.5 kg
PACKAGING WEIGHT	172 lbs / 78 kg
DIMENSIONS (DWH)	23.2" x 22.4" x 40.9" 590 x 570 x 1040 mm
PACKAGING DIMENSIONS	25.2" x 24" x 45.7" 640 x 610 x 1160 mm

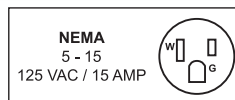

OMCAN INC.

Telephone: 1-800-465-0234

Fax: (905) 607-0234

Email: sales@omcan.com

Website: www.omcan.com



Follow us to keep up to date with the latest news and offers

